



STEATITE UNMANNED SOLUTIONS



TECHNOLOGY FOR EXTREME ENVIRONMENTS



UGV



UAV



USV



WWW.STEATITE-COMMUNICATIONS.CO.UK



WAVE RELAY® UNMANNED SOLUTIONS

Wave Relay® is the most powerful, most scalable, and most versatile Mobile Ad-Hoc Network (MANET) datalink in the world. Replace many systems on your unmanned platform with one Wave Relay® node and save on size, weight, power, and cost whilst simultaneously increasing performance, versatility, range and capability.

Unmanned platforms have already transformed the way we operate, but UAVs, UGVs and ASVs equipped with Wave Relay® take it a step further. Because all these unmanned platforms are on the Wave Relay MANET, any operator in the network can stream video directly from them – or even control them.

The low SWaP solution you've been looking for

Access all capabilities on a single device through Wave Relay® Ecosystem devices that communicate on a standardized, common network. You no longer need to carry separate radios for separate devices and capabilities, reducing weight on your kit and allowing you to view live data streams from any networked asset at anytime from anywhere.

Weighing in at just 90g and measuring 8.35 x 5.08 x 1.5 centimetres in size, Wave Relay® is extremely compact, making it the ideal choice for integration into an unmanned platform.

The radio is now your computer

Wave Relay® on-board Android™ operating systems allows you to install and run 3rd party applications directly on the device. As a smart radio, Wave Relay® is a network and mobile computing platform that works simply and easily.

Install a command and control app onto a Wave Relay® node to control all your unmanned systems directly from the device while monitoring their movement via situational awareness apps and/or the Wave Relay® Video Decoding app.





WAVE RELAY® UNMANNED SOLUTIONS

A versatile command and control datalink

UGVs, UAVs, and sensors on a standardized network are the building blocks towards a future where your networked devices will not only perform their discrete functions but also collaborate in new, ground-breaking ways.

By sharing a common network, Wave Relay® allows multiple unmanned systems and operators to talk to each other and share data between devices. An integrated Android™ computer allows you to build a foundation for data fusion, artificial intelligence, and in-network computing.



Go where other radios can't

A Wave Relay® radio system is built on 3x3 Multiple Input Multiple Output (MIMO) technology. MIMO technology allows for extended range and increased throughput in complex urban, subterranean, and maritime environments – both line-of-sight (LOS) and non-line-of-sight (NLOS).

Ideal for Unmanned Systems, the MPU5 can extend your network to maintain communications with your unmanned systems wherever they need to go.



Stream HD video

Wave Relay® radio nodes enable you to encode and stream live audio and video without the need for external hardware encoders by directly connecting HD and SD camera systems via 3G-SDI, HDMI, and Composite video inputs.

Wave Relay® nodes encode and stream H.264 feeds at resolutions ranging from 320x240 to Full HD 1080p and 720p. The on-board hardware accelerated video encoder supports RTP as well as both unicast and multicast UDP streaming in an MPEG-TF transport stream.

The MPU5 also provides hardware accelerated H.264 video decoding, enabling you to watch up to four video streams simultaneously.

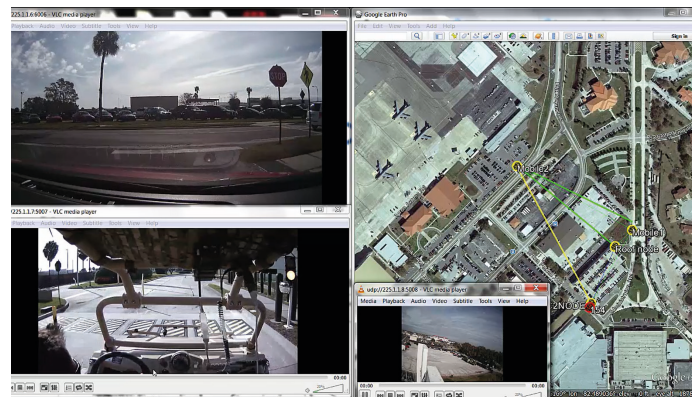



WAVE RELAY® UNMANNED SOLUTIONS

MANET networking for voice, data and video

A Wave Relay® MANET allows a distributed and decentralized group of fully mobile users to communicate continuously and efficiently without the need for fixed infrastructure.

Every Wave Relay® radio node on a network communicates with each other, forming a true peer-to-peer network with no master node or base station. Add and subtract Wave Relay® nodes from the network without losing connectivity or reconfiguring your devices.

The Wave Relay® MANET routes data from radio node to radio node, enabling the network to grow, adapt, and extend as more nodes are added. Massively scalable and incredibly intelligent – a Wave Relay network keeps you connected and ready for anything.

Swarming and autonomy

UGVs, UAVs, and sensors on a standardized network are the building blocks towards a future where your networked devices will not only perform their discrete functions but also collaborate in new, ground-breaking ways.

By sharing a common network, Wave Relay® allows multiple unmanned systems and operators to talk to each other and share data between devices.

An integrated Android™ computer allows you to build a foundation for data fusion, artificial intelligence, and in-network computing.





WAVE RELAY® UNMANNED SOLUTIONS

Wave Relay® Auto Tracking Antenna System

The Wave Relay® Tracking Antenna is a deployable system that works in concert with Wave Relay radio nodes to deliver high throughput at long ranges to keep you in constant communication with your aircraft.

Disassembling into five, easy-to-transport cases, the system can travel with you wherever you go. Long range high throughput communication to manned and unmanned aircraft has never been so simple.

The Wave Relay® Tracking Antenna supports 360° continuous rotation operation and less than 1° pointing accuracy for bidirectional communication out to a maximum range of 135 miles (200km).

The antenna supports interchangeable RF modules, allowing for operation in L-, S- and C-Band.

Designed for a two-person assembly in under 15 minutes, the sectional parabolic dish disassembles for easy transport in five separate rollable cases that can ship via standard shipping.

Tracking Antenna gain: 24dBi (L-Band), 28dBi (S-Band), 35dBi (Lower C-Band) and 36dBi (Upper C-Band)

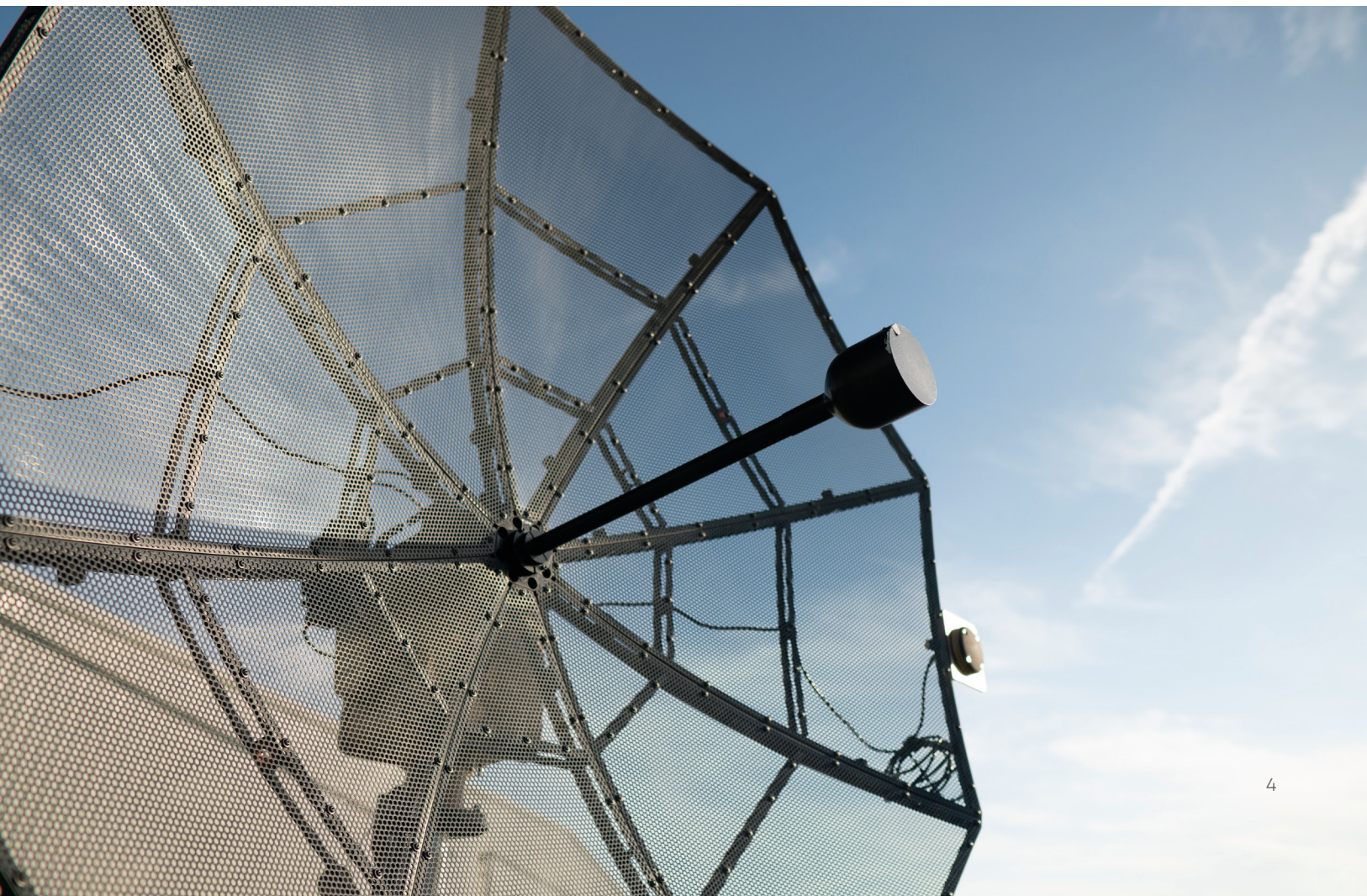



WAVE RELAY® UNMANNED SOLUTIONS

Wave Relay® Display

Designed specifically for use with autonomous platforms, the Wave Relay® display is intended to provide an interface between operator and vehicle.

Control your UAV or UGV directly from the display, which in turn is connected directly to the Wave Relay® radio. Seamlessly interact with applications installed on your Wave Relay® radio through the display.

Dual analogue thumb-sticks provide control with pin-point accuracy, whilst physical configurable shortcut keys can be programmed to quickly access your most frequently-used commands. The display is the ultimate command & control interface for autonomous platforms using Wave Relay®.

Wave Relay® Man Portable Unit (MPU5)

Operate your autonomous vehicles from a ground control station equipped with a Wave Relay 5 node or use the MPU5. Designed to be hand-carried, the MPU5 is a battery-powered dismounted radio.

The MPU5 forms an integral part of any Wave Relay® network, acting as a portable radio for voice, data and video. The MPU5 can be connected to a Wave Relay® display via a unique dual PTT device, allowing the operator to control and provide instruction to a remotely operated vehicle.

A MANET created by Wave Relay® nodes allows any operator equipped with an MPU5 and display with the ability to remotely control an autonomous vehicle or receive multiple HD video streams from a vehicle. Now you can equip your team on the ground with live real-time video from your 'eyes in the sky'.





WAVE RELAY® UNMANNED SOLUTIONS

Why should you choose Wave Relay® for your unmanned solutions?

UAV, UGV and ASV communication systems powered by Wave Relay® technology create a foundation to support machine-to-machine communication where data can be fused into actionable intelligence. Wave Relay® communication systems facilitate the needs autonomous platforms where everyone and everything operates on the same network. Unmanned vehicles, sensors, and their associated operators have access to every platform's capabilities through the integrated Android™ computer available on every Wave Relay®-enabled device, providing users with the option to drive any UGV, fly any UAV, steer any camera, and operate any sensor from a single device.

Key features of the Wave Relay® MPU5 Radio

- 100+ Mbps of data throughput : the fastest data throughput of any MANET radio system currently available
- Low risk : Wave Relay® is already the MANET of choice for some of the largest UAV and robotics companies in the world
- 3x3 MIMO utilizes multipath and spatial multiplexing to deliver best in class performance
- Unparalleled range for a MANET communications system
- Native RS232 for compatibility with Command & Control systems, Autopilots, Sensors, Cameras and Payload Electronics
- 6W and 10W RF modules provide the highest RF transmit power of any MANET system, reducing the need for amplification
- Video encoder embedded directly within the radio : reduce weight on your UAV/UGV/ASV by using the built-in encoder
- The only MANET system to incorporate an Android computer directly within the radio - install your own .apk files
- USB and Ethernet connectivity available for your on-board systems
- Integrated GPS module accurate to within 2 metres : GPS module can also accept input from external GPS sources
- Ultra-low latency self-forming / self-healing network : Nodes hop and join the network within an average of 2ms
- Encrypted to AES-256 : Accredited to FIPS 140-2 Level 2 with Suite B algorithms
- Multicast video streaming allows for streaming video concurrently to multiple subscribers
- All MANET topologies supported including star, hub/spoke, series/relay, fixed backbone infrastructure, and hybrid
- Supports Radio over IP (RoIP) tethering to SATCOM / 4G / LTE / 5G / legacy radio systems
- Supports frequencies between 1350MHz and 6000MHz using interchangeable RF modules
- Modular design allows you to upgrade your system using different RF modules in the future
- No command node required and no limit to the amount of hops
- Suitable for use on virtually all UAV, UGV and ASV platforms.





WAVE RELAY® EMBEDDED MODULE

The Embedded Module unites your unmanned system's communication, computing, and video subsystems into a single SWaP-timised package. Replace separate and specialized equipment with a single Embedded Module that performs the same functions but takes up less space, weighs less, consumes less power, and costs fewer dollars and engineering hours to integrate. Leverage your SWaP savings to accomplish what matters most: the mission, time on station, and the payloads you carry.

Transform your systems into a network

By integrating the Embedded Module into your unmanned systems and sensors, you turn them into networked assets.

Each system with an Embedded Module extends the Wave Relay® MANET, allowing your users to access services - such as video or sensor data - on any node from anywhere.

In addition, unmanned systems and sensors from multiple manufacturers can now communicate on a common network, giving your products more opportunities to perform.

Achieve the vision

The Embedded Module brings your unmanned platform into the Wave Relay® Ecosystem, where all UAVs, UGVs, sensors, and systems are networked.

MPU5 radio users can now operate your platforms, watch your video feeds, and steer your cameras. By establishing a network of unmanned systems, swarming, autonomy, and collaborative behaviours are now possible. The sky is no longer the limit.





WAVE RELAY® EMBEDDED MODULE

Processor	1GHz Quad Core ARM
Memory	2GB Memory Onboard
Storage	128GB Flash
I/O Interface	GPS HDMI In 3G-SDI / Composite In Control (Sleep / GPIO / Zeroize / 1PPS / GND) RS-232 Serial USB OTG Ethernet Audio In (Mic) Audio Out (Speaker)
Networking	10/100 Mbps Ethernet Integrated Serial-to-Ethernet Seamless Layer 2 Network Cloud Relay Compatible Advanced Multicast Algorithms IPv4 & IPv6 Compatible Integrated DHCP Server USB RNDIS Host & Device
Video Input	3G-SDI / Composite / HDMI
Video Compressions	H.264 Encoding & Decoding Native Scaling
Frame Rates	6 / 10 / 15 / 24 / 29.97 / 30 / 59.94 / 60 fps 59.94 / 60 fps Not Available at 1080p
Resolutions	240p / SD 480 / SD 576 PAL / 720p / 1080p

Bit Rates	500 Kbps ~ 20 Mbps
Network Protocols	UDP Multicast & Unicast (MPEG-2 Transport Stream) RTP Multicast & Unicast RTSP Unicast
Security	CTR-AES-256 Encryption SHA-256 HMAC Cryptographic Acceleration Suite-B Algorithms
MANET	Wave Relay® Self-Forming / Healing Peer-to-Peer No Master Node
Node Entry	<1 Second
Max No. of Hops	No Limit
Max No. of Nodes	No Limits
Max Distance Between Nodes	130 Mi
Weight	3.2 oz.
Dimensions	2.00 3.29 x 0.59 in.
OS	Android™ 5.0 (Lollipop)
Operating Temperature	-40°C to 85°C
MIL-STD-810G	Vibration High Temperature (Operational) High Altitude (Operational)
Power Input	8 - 30V DC

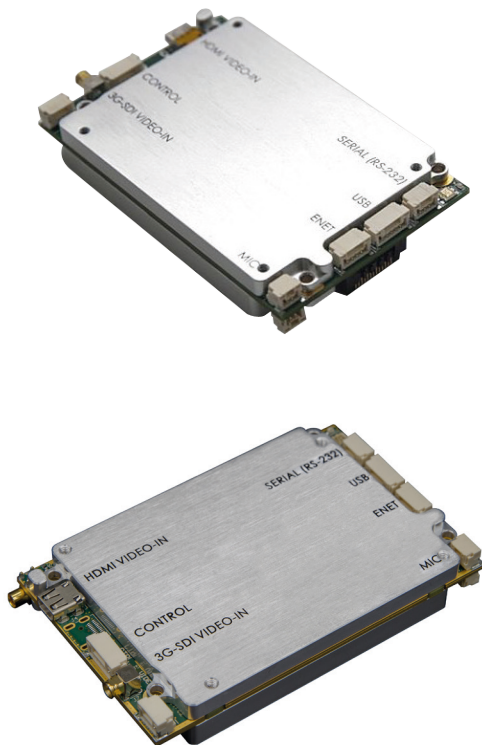

Radio Type	Configuration (MIMO)	Average		
		Idle (Rx)	20% Tx Duty Cycle	Transmit
L-Band MIMO Radio P/N: RF-1100	3x3, 2W/Chain	5.06	9.08	23.20
	2x2, 2W/Chain	4.90	7.70	17.20
	3x3, 1W/Chain	5.04	8.55	20.40
S-Band MIMO Radio P/N: RF-2100	3x3, 2W/Chain	4.28	11.97	40.80
	2x2, 2W/Chain	4.14	9.23	27.20
	3x3, 1W/Chain	4.26	10.21	31.60
Higher Power S-Band MIMO Radio P/N: RF-2150	3x3, 3.2W/Chain	5.08	12.16	41.20
	2x2, 3.2W/Chain	5.02	9.55	28.40
	3x3, 1W/Chain	5.16	9.37	27.60
	3x3, 2W/Chain	5.08	11.03	34.40
	2x2, 2W/Chain	5.04	8.73	26.10
Lower C-Band MIMO Radio P/N: RF-4100	3x3, 2W/Chain	7.86	18.50	60.80
	2x2, 2W/Chain	7.18	14.30	42.80
	3x3, 1W/Chain	7.80	16.35	51.60
Upper C-Band MIMO Radio P/N: RF-5100	3x3, 1.3W/Chain	5.42	15.11	54.40
	2x2, 1.3W/Chain	5.12	11.34	38.40
	3x3, 1W/Chain	5.42	13.77	47.60



UNMANNED AERIAL VEHICLE (UAV) DATALINK

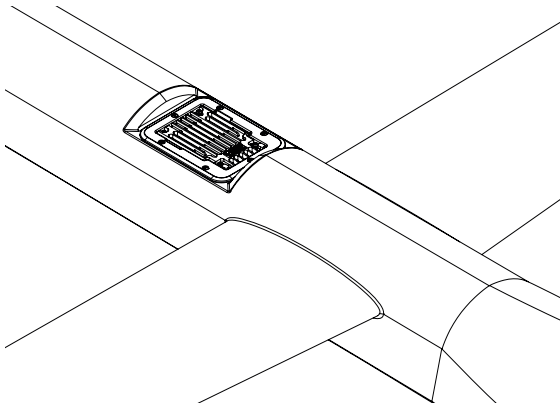

An unmanned aerial vehicle equipped with Wave Relay® as its primary datalink will provide unparalleled throughput at range. The maximum throughput supported by Wave Relay is over 100Mbps, whilst the range between two nodes when using the Wave Relay® tracking antenna can exceed 200km.

Replace many systems on your unmanned platform with one Wave Relay radio system and save on size, weight, power and cost. Your Android control application installs directly onto the Wave Relay radio enabling a single smart radio to fly all of your unmanned systems. Your

entire fleet of unmanned systems can now operate and communicate on a common network. A Wave Relay® radio module can replace the need for separate video encoding capability, video & RF transmitters, computing power and air to ground command and control datalink.

A Wave Relay® MANET system can also interface with secondary communication platform such as SATCOM or 4G, providing datalink redundancy extending the range of your UAV platform exponentially.

Using the Radio over IP (RoIP) capability of Wave Relay® allows you to tether together a Wave Relay® node with another communication system to allow your UAV to use longer range low bandwidth communication methods when flying beyond the range of the primary Wave Relay® network. Control your UAV over a Wave Relay® encrypted network from anywhere in the world.

Whilst Wave Relay® can be used on any UAV platform, it is typically best suited to medium altitude long endurance (MALE) platforms classified in the Group 2 and Group 3 categories (Tier II).

UAV Group	Max Weight (kg)	Operating Altitude (ft.)	Speed (Knots)	Representative UAV
1	0 - 9	< 1,200 AGL	100	RQ-11 Raven, Wasp
2	10 - 25	< 3,500 AGL	< 250	ScanEagle
3	25 - 600	< 18,000 AGL	< 250	RQ-78 Shadow, RQ-21 Blackjack
4	>600	< 18,000 AGL	Any airspeed	MQ-8B Fire Scout, MQ-1A/B Predator
5	>600	< 18,000 AGL	Any airspeed	MQ-9 Reaper, RQ-4 Global Hawk

UAV platforms which exclusively use Wave Relay® as the air-to-ground communications datalink include;



Hovefly® Livesky™



Insitu Integrator®



Insitu ScanEagle®



Insitu ScanEagle® 3



Martin UAV V-Bat



UNMANNED GROUND VEHICLE (UGV) DATALINK

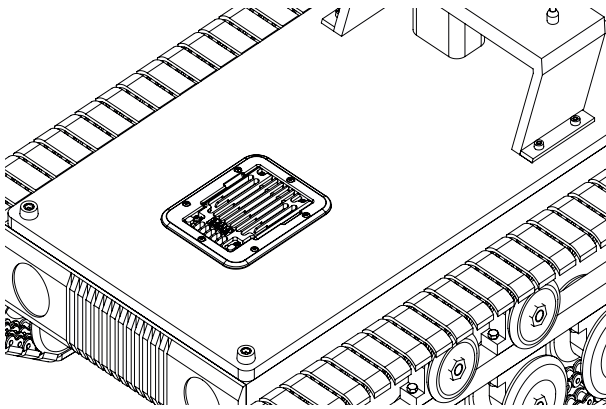

Integrate Wave Relay® directly into your UGV systems. Wave Relay® has been specifically designed to operate in RF-challenging environments. UGVs equipped with a Wave Relay® datalink can be used for many applications where it may be inconvenient, dangerous, or impossible to have a human operator present.

Generally, the vehicle will have a set of sensors to observe the environment, and will either autonomously make decisions about

its behaviour or pass the information to a human operator at a different location who will control the vehicle through teleoperation. When it comes to the command and control of the vehicle, Wave Relay® offers unparalleled performance in the datalink provided between operator and vehicle.

Wave Relay® can be embedded within your UGV platform to offer the best possible datalink in urban, underground, open field and tunnel environments. Offering over 100Mbps of data throughput the datalink provided by a Wave Relay® radio is capable of providing multiple streams of crystal-clear HD video, with plenty of bandwidth available for Command & Control, and payload data.

Utilising the unique interchangeable RF module design from Persistent Systems, Wave Relay® radios can operate in L-Band, S-Band or C-Band frequencies to ensure that you get best possible performance in virtually all environments. Wave Relay® has been tested on remotely-operated vehicles operating in tunnels and underground environments which are unreachable by humans. The MIMO capabilities of the radio make best use of RF reflection and refraction to offer superlative performance in

Benefits of using Wave Relay® for UGV applications include:

- Reduces the weight of your UGV by removing redundant hardware in favour of a single Wave Relay® system
- Increases operating time of your UGV by having less weight to carry and less systems to power
- Consolidates all of your complex UGV tasks onto one reliable platform
- Keeps the operator at a safe distance from the robot without compromise to operational performance
- Use the same datalink for command & control, video, payload data reach-back
- Use your UGV in RF-challenging environments – C-Band is recommended for urban environments
- Allows multiple users on the ground access to live real-time video feeds from an airborne platform
- Each UGV node extends the overall reach of your Wave Relay® network
- Gives multiple operators the ability to control the UGV

Whether you're exploring an underground tunnel or defusing an IED, Unmanned Ground Vehicles are an important part of your team's toolbox. UGVs in the Wave Relay® Ecosystem come in a variety of form factors – all MANET-ready, giving any operator the ability to see what the UGV sees. UAV platforms which exclusively use Wave Relay® as the air-to-ground communications datalink include:



Endeavour Robotics
Firstlook®



Endeavour Robotics
Packbot®



Endeavour Robotics
Kobra™



Endeavour Robotics
SUGV



Qinetiq Talon®



Qinetiq Titan



UNMANNED SURFACE VEHICLE (USV) DATALINK

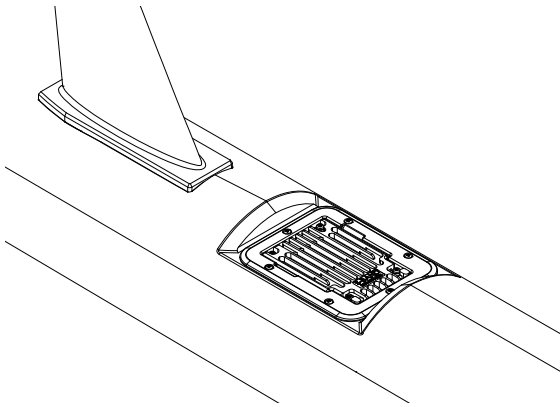

Integrate Wave Relay® directly into your Autonomous Surface Vessels. Wave Relay® has been proven to work as a reliable communications platform for unmanned, autonomous or remotely-operated vehicles.

As greater levels of autonomy are being explored Autonomous Surface Vessel (ASV) manufacturers, Wave Relay® opens the floodgates on the volume, speed and reliability of data passed between autonomous vessel and operator. The Wave Relay® datalink can be used as a dependable means of Command & Control, whilst concurrently offering a link for payload data, multiple streams of HD

video, and situational awareness. In addition to development of your own maritime solution using the Wave Relay® embedded module, Steatite has developed a bespoke mast mount antenna solution. Designed to be installed up a ship's mast, the Steatite Datalink Repeater has been specifically developed for ASV requirements.

Equipped with a single umbilical cable for both power and data, the Datalink Repeater is a low-maintenance device which can remain permanently mounted on a pole or mast to relay information between the ASV and other vessels or shore stations. Offering the same 100+ Mbps performance as can be found in all Wave Relay® products, the Steatite Datalink Repeater is proven to offer the fastest, most reliable secure encrypted link for Command & Control, telemetry, payload data, voice and video.

Tested to operate at ranges up to 40km and over for shore to ship communication the Steatite Datalink Repeater can be tethered to legacy data communication systems such as SATCOM, 4G/5G, and the Internet, the operating range of the Wave Relay® network can be extended to operate worldwide.

Benefits of using Wave Relay® for ASV applications include;

- Increased operational range of your remotely-operated vehicle – over 40km tested with omni-directional antennas
 - High speed data throughput at range, supporting multiple concurrent streams of HD video, data and voice
 - Over-the-horizon communication
 - Make use of the Evaporation Duct when operating in C-Band to push out your communication datalink even further
 - Interchangeable RF module allows for operations in L-Band, S-Band and C-Band RF frequency spectrums
 - Tether together Wave Relay® with other radio systems (SATCOM, 4G) for redundancy and range extension
 - Trusted platform – over 40,000 Wave Relay® devices in service
 - Integrated GPS module for situational awareness
 - ICD (Interface Control Document) and API (Application Programming Interface) available to aid with integration
- Unrivalled, proven performance – already in use by some of the most respected ASV companies in the world

In addition to the use of Wave Relay® by ASV manufacturers for conventional command and control applications, Wave Relay® is also in use for scientific research applications. The Marine Applied Physics Corporation (MAPC) Remote Off-Shore Sensor System which is a deployed moored sensor platform for air, surface and subsurface environmental sensing. Wave Relay® is used for the purposes of secure data, video and voice, real time position location, and offering a consistent 30+ Mbps of multicast throughput for payload data.



WAVE RELAY® UNMANNED SOLUTIONS

Antenna selection for Wave Relay® Unmanned Solutions

Whilst often overlooked, choosing the right antenna for your unmanned platform is absolutely critical to the performance of your Wave Relay® datalink. Steatite has been at the forefront of antenna design and manufacture for over 40 years and continues to excel in the research, design and manufacture of ultra-wideband microwave antennas, subsystems and associated microwave components.

With systems in operation across the world and space, our reach is truly global. Steatite custom designed and built antennas are at the pinnacle of antenna development. Our purpose built UK antennas facility is a centre of excellence for the manufacture and testing of advanced microwave and RF antennas. Let us help you to choose the right antenna for your unmanned platform.

* Images not to scale



The following chart shows an approximate indication of throughput at range using the above antenna options. These figures are calculated estimates based upon Steatite's experience during testing.

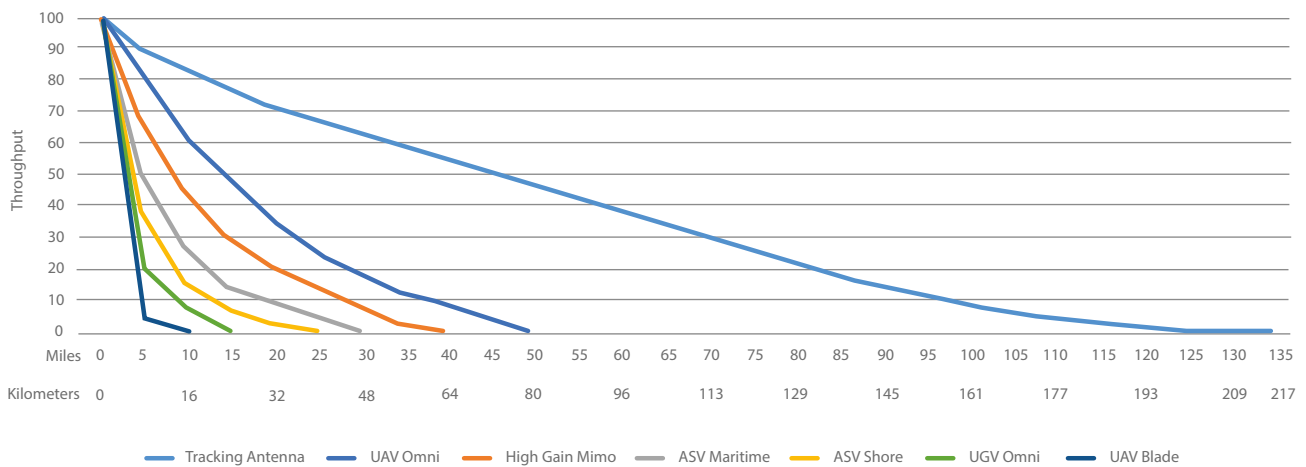

The values shown in the above table are for illustration only and represent a best case scenario. These values will differ greatly depending on the frequency band used, RF power output, environmental influences, RF interference, geography and topology, antenna height, RF channel bandwidth, physical obstruction, antenna spacing and several other contributing factors. Steatite has a catalogue of trial reports produced during our real-world test of the Wave Relay® radio in different environments, for different applications and with a variety of different clients. We would be pleased to share these results with you.



WAVE RELAY® EMBEDDED MODULE INTEGRATION

Integrate the Wave Relay® Embedded Module into your products to unite UAVs, UGVs, ASVs and sensors on a single network. Because the Embedded Module features an HD video encoder and Android™ computer on-board, eliminate redundant equipment from your platform.

The Wave Relay® Embedded Module unites your unmanned system's communication, computing, and video subsystems into a single SWaP-timized package.

Replace separate and specialized equipment with a single Embedded Module that performs the same functions but takes up less space, weighs less, consumes less power, and costs less with the added

benefit of taking fewer engineering hours to integrate. Leverage your SWaP savings to accomplish what matters most: the mission, time on station, and the payloads you carry.

Wave Relay® operates at the OSI Layer 2 level. It can pass through all IP-based data, essentially operating as a secure network switch for all of your unmanned systems, sensors, mission computers, data payloads, video cameras, autopilots and Command & Control systems.



UNMANNED AERIAL VEHICLE INTEGRATION

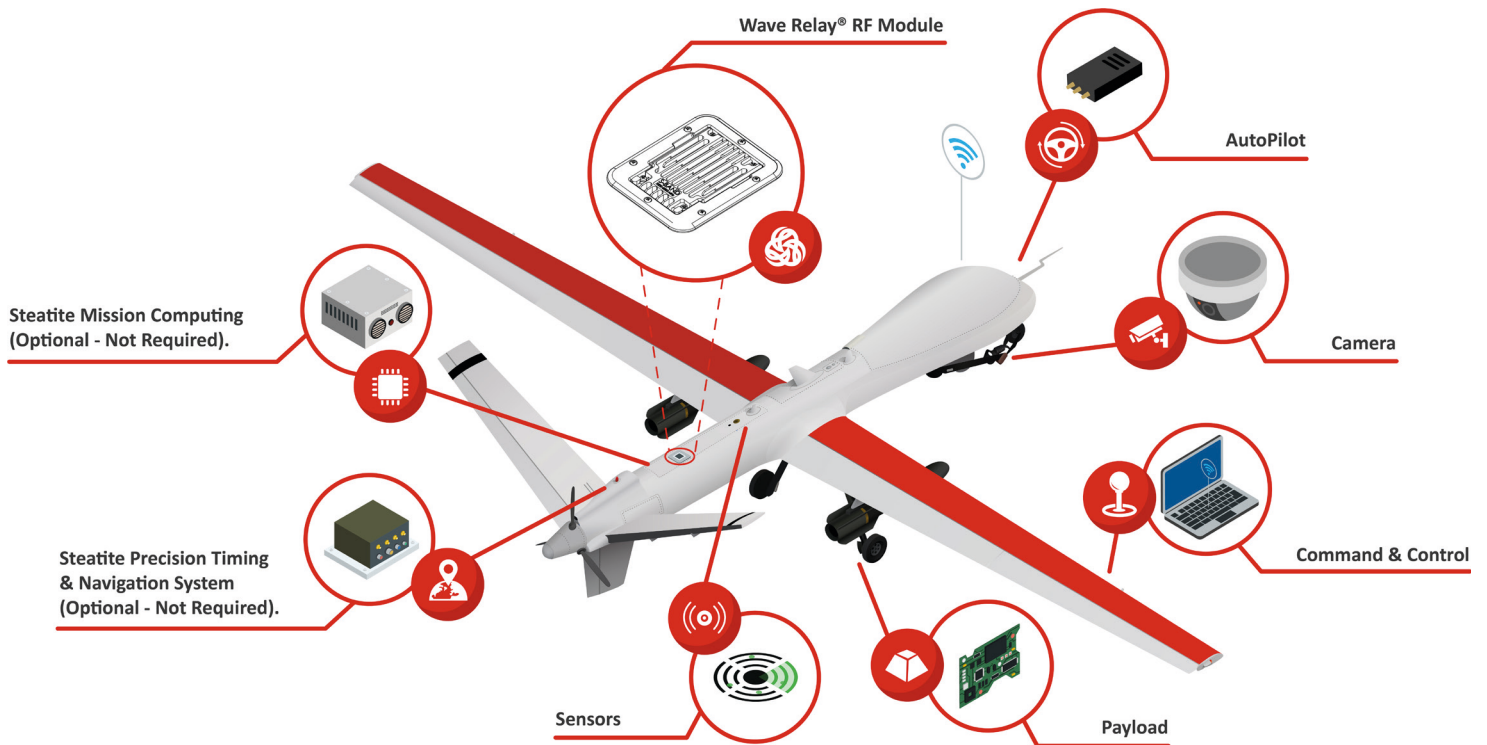



UNMANNED GROUND VEHICLE INTEGRATION

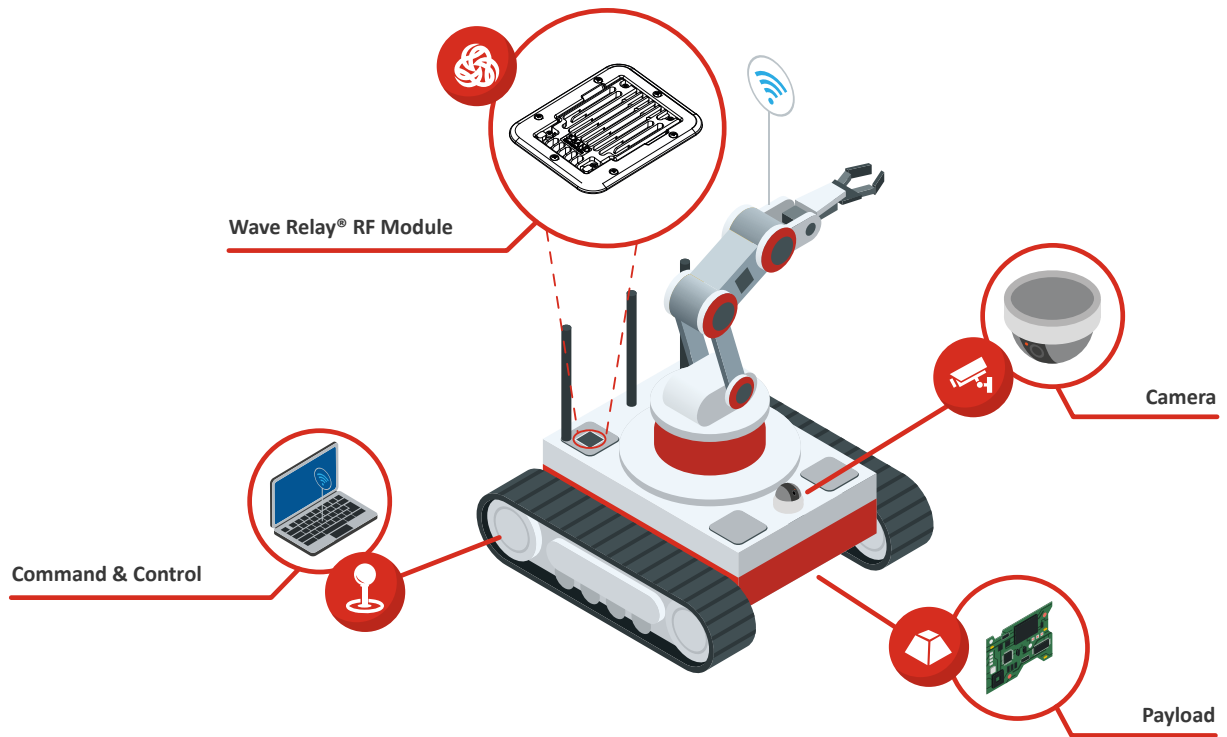

AUTONOMOUS SURFACE VESSEL INTEGRATION

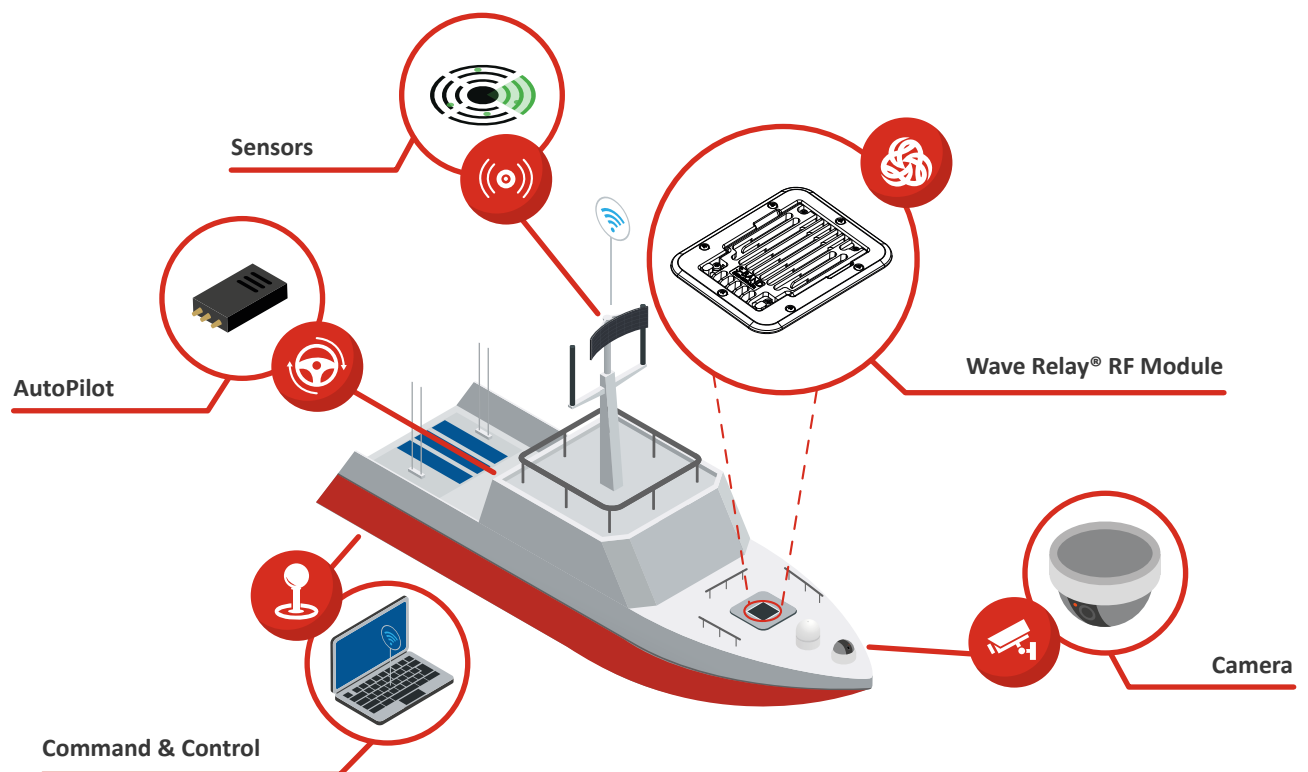



POSITION, NAVIGATION & TIMING SYSTEMS

High Precision Position and Navigation System for Unmanned Platforms

The VersaPNT® is a high-performance inertial navigation sensor that delivers accurate, software-configurable position, navigation, attitude, time, and frequency signals under all circumstances – even in GNSS-denied environments. Additionally the VersaPNT® is a GNSS time and frequency source and network time server for your time-critical systems.

The VersaPNT® integrated Inertial Measurement Unit (IMU), in combination with its precision oscillator, will provide your unmanned platform with accurate Position, Navigation and Timing (PNT) data until a trusted GPS signal returns.

VersaPNT® will take any application that has a critical need for PNT data to the next level of reliability and accuracy. VersaPNT® has been designed specifically for air/land/sea applications including:

- Synchronization reference for unmanned systems command and control
- Observation payloads (reconnaissance, surveying)
- Mobile communication systems
- Land-based vehicle navigation
- Ground, maritime, and air tactical navigation
- ISR signal analysis

VersaPNT® minimizes size, weight and power (SWaP) by combining the PNT functions that are typically achieved only with multiple independent subsystems into one portable unit with modular architecture. This makes the VersaPNT® the ideal choice for weight-sensitive unmanned platforms.





High Accuracy Time & Frequency Synchronization for Ground Control Stations

SecureSync® is a high accuracy time synchronization platform for military and commercial operations. SecureSync® is a security-hardened network appliance designed to distribute timing data across your network to ensure all of your ground station systems are accurately synchronized. The modular design of the SecureSync® platform allows for user-configurable input from a variety of timing sources. This time synchronization data can then be distributed across your entire network in a variety of protocols to ensure all of our ground station systems communicate in harmony.

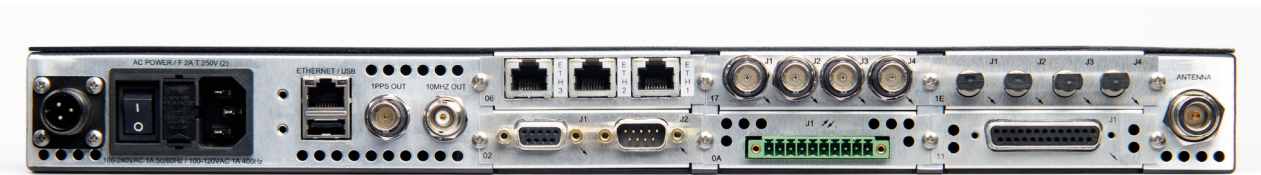

Up to six cards can be accommodated inside the SecureSync® platform. They can be purchased as part of the original configuration or added at a later date to keep up with the changing needs of your ground control system.

Supported time reference sources include;

- GPS
- GLONASS
- Galileo
- BeiDou
- Iridium

Supported time reference protocols include;

- GPS
- NTP / PTP
- iRig
- Havequick
- Others...

Output modules include;

- NTP
- 1PPS
- 10MHz
- Others...

Combining precision master clock technology with exceptional configurability, SecureSync® delivers the industry's highest standards for extreme reliability, security, redundancy, and flexibility in a rugged, modular, cost effective form factor. Designed to meet rigorous network security standards and best practices, it ensures accurate timing through multiple references, tamper-proof management, and extensive logging. SecureSync® is also the only time and frequency reference system listed on the Defence Information Systems Agency (DISA) Department of Defence Information Network (DoDIN) Approved Products List (APL).



GPS JAMMING PROTECTION

GPS Anti-Jam Antenna

The 8230AJ GPS/GNSS Anti-Jam antenna is designed to operate effectively in the presence of a threat to the situational awareness of your unmanned system.

A standard GPS antenna sees the entire view of sky, equally receiving signals from satellites at the horizon or the zenith and all points in between. However, there is increasing interference in the GNSS L1 band, whether unintentional from other transmitters like communications towers or intentional from illegal "privacy jammers".

The AJ antenna rejects signals for the lower elevation angles - where most of the interference comes from - and only receives signals from the higher elevation angles where the satellites are.

Of course, this reduces the number of satellites the receiver will see, but for the timing application, only a few satellites are needed. Moreover, with multi-constellation receivers, there are an increasing number of satellites available.

So you get all the performance in timing accuracy you would get with a standard antenna plus 20 dB or more of interference rejection.





NEXT GEN WAVE RELAY® GROUND CONTROL STATION

Developed by Steatite, the CRiB Ground Control Station is a portable, deployable management console for your Wave Relay® MANET. Monitor multiple video streams, sensor data, situational awareness and more, all from one convenient management platform.

Designed to fully integrate with your Wave Relay® network, the CRiB contains embedded Wave Relay® technology to directly interface with your MANET out of the box.

Featuring a unique dual-screen setup, the CRiB provides a user-configurable interface, allowing you to manage your MANET whilst providing a means of Command & Control for your unmanned platform.



The CRiB contains two computers – the primary system is based on the Microsoft Windows platform, whilst the secondary system is based on Android. The second display can toggle between Windows and Android operating systems at the flick of a switch, all without the need to restart your applications. Use the Android platform to run TAK or other tactical situational awareness packages on the large screen, or install your own .apk files onto the system.



The CRiB allows you to operate and manage autonomous systems deployed in a high threat environment, all from the safety of a remote location.

View live video streams being broadcast over a Wave Relay® MANET, make critical decisions based on the situational awareness or take control of any one of the remotely-operated vehicles or sensors available on the Wave Relay® network.

The CRiB can be battery powered from two optional internal battery packs, or use an external power source if you intend to manage a Wave Relay® MANET for longer operations.

CRiB - Cloud Relay® compatibility

Extend the reach of your MANET worldwide using the embedded Cloud Relay® capabilities. Based on enterprise-level Cisco routing protocols, the CRiB will bridge together geographically-separate MANET networks using fixed infrastructure. Cloud Relay® creates point to multipoint GRE tunnel across IP networks, such as the Internet.

The protocols used during this data exchange allow the CRiB to establish and maintain secure tunnels with peer Wave Relay® Ground Control Stations. The integrated Cloud Relay® capability provides confidentiality, data integrity, access control, and data source authentication between Wave Relay® nodes on a MANET.

See how we can help

If you have a Wave Relay® requirement then contact us on 01527 512400 or email communications@steatite.co.uk.

For more information regarding the Wave Relay® Ecosystem visit www.steatite-communications.co.uk



STEATITE LTD (COMMUNICATIONS)
Ravensbank Business Park,
Acanthus Road, Redditch,
Worcestershire,
B98 9EX
Telephone: +44 (0)1527 512 400
Email: communications@steatite.co.uk

TECHNOLOGY FOR EXTREME ENVIRONMENTS

WWW.STEATITE.CO.UK



COMPUTING



BATTERIES



COMMUNICATIONS



ANTENNAS



IMAGING

